

AUTOMATIC SEWING SYSTEMS

AUTOMATIC U-SEAMING AND DIAMOND
GUSSETING MACHINE

GLC36

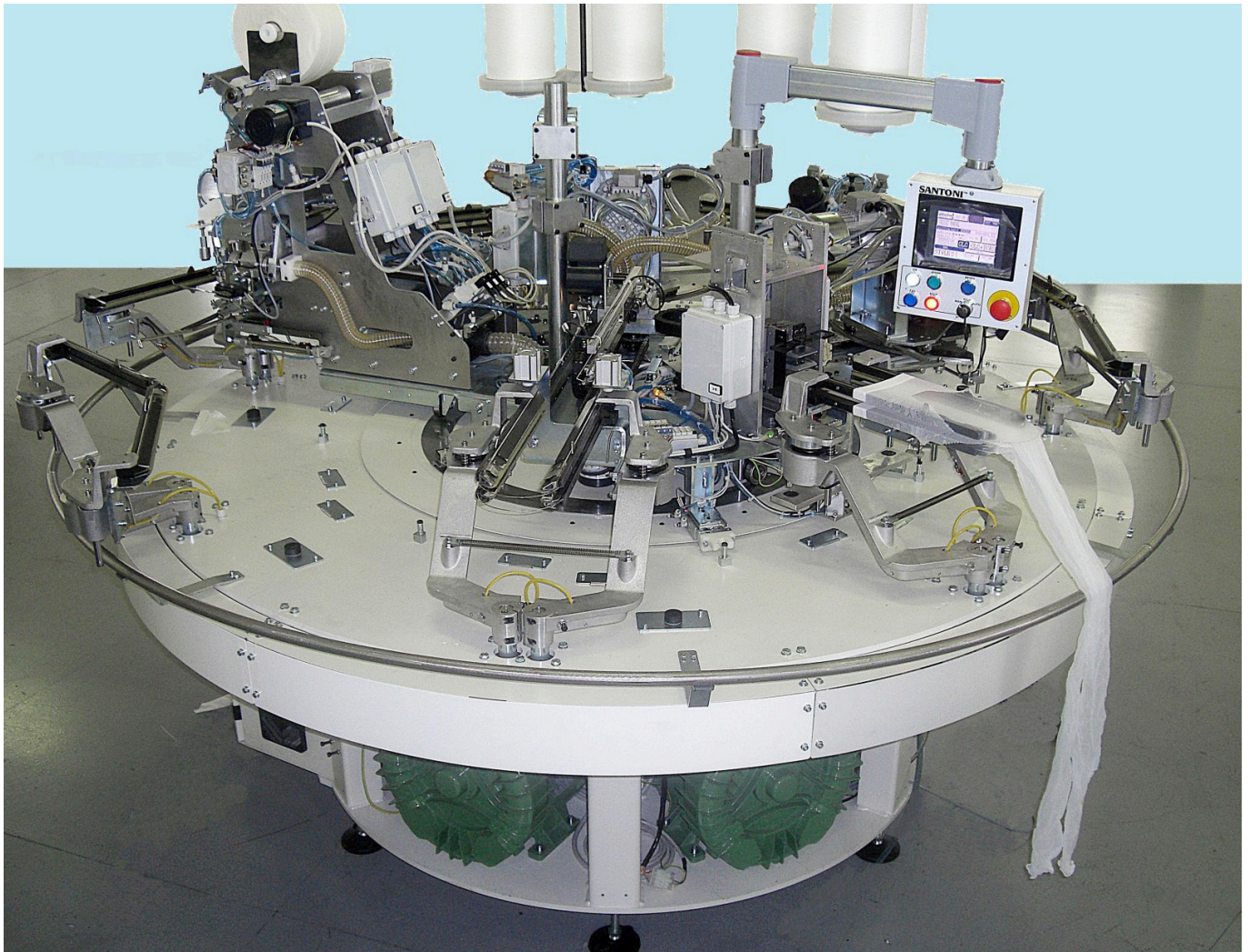

AUTOMATIC SEWING SYSTEMS

GLC36

The new pantyhose seaming machine entirely developed and built by Santoni allows the gusset insertion during the station rotation, avoiding a significant production loss present on actual machines.

AUTOMATIC SEWING SYSTEMS

GLC36

Specification	Value
Dimensions	Ø 2.500 x 2.100 (h) mm
Sewing heads	Nr. 2 Union Special 9M
Clamps	Nr. 7 - 360 mm
Air pressure	6 bar
Air consumption	320 NI/min
Absorbed power	7,5 Kw
Minimum cycle time	6,5 Sec.
Max. Production	46 Dz/hr (pair)

Caratteristiche
Qty. 7 clamps with solenoid closing system
Qty. 2 external electrical rails to operate the clamps make the maintenance easier
A specific brush for each solenoid allows an independent side opening and closing
Wide clear area around loading station
Single positioning device (SP) for waistband or double positioning device (DP) to correctly align waistband and crotch
Scissors device with inverter motor
New gusset cutting and inserting station synchronised with forms rotation
Longer time to correctly positioning the gusset fabric
Longer time to complete the sewing operation
Linking to the toe closer
Toes shaping system

Applications: Underwear, Sportswear, Swimwear, Medical Textiles, Technical Textiles.

DIAMOND GUSSET

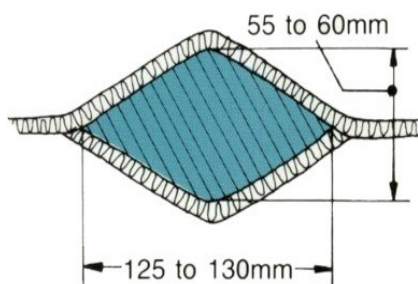

DIAMOND GUSSET SEAM

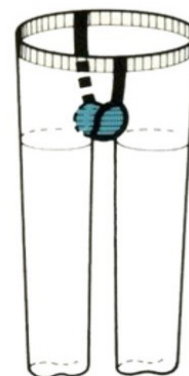

DISCLAIMER:

Technical data given in this brochure are for information only. Santoni S.p.A. reserves the right to modify the machine features without forewarning and without the obligation to apply any modification to the machines already installed. Pictures are exemplifying and have not to be regarded as a reference.

Santoni is recommending needles from
GROZ-BECKERT®

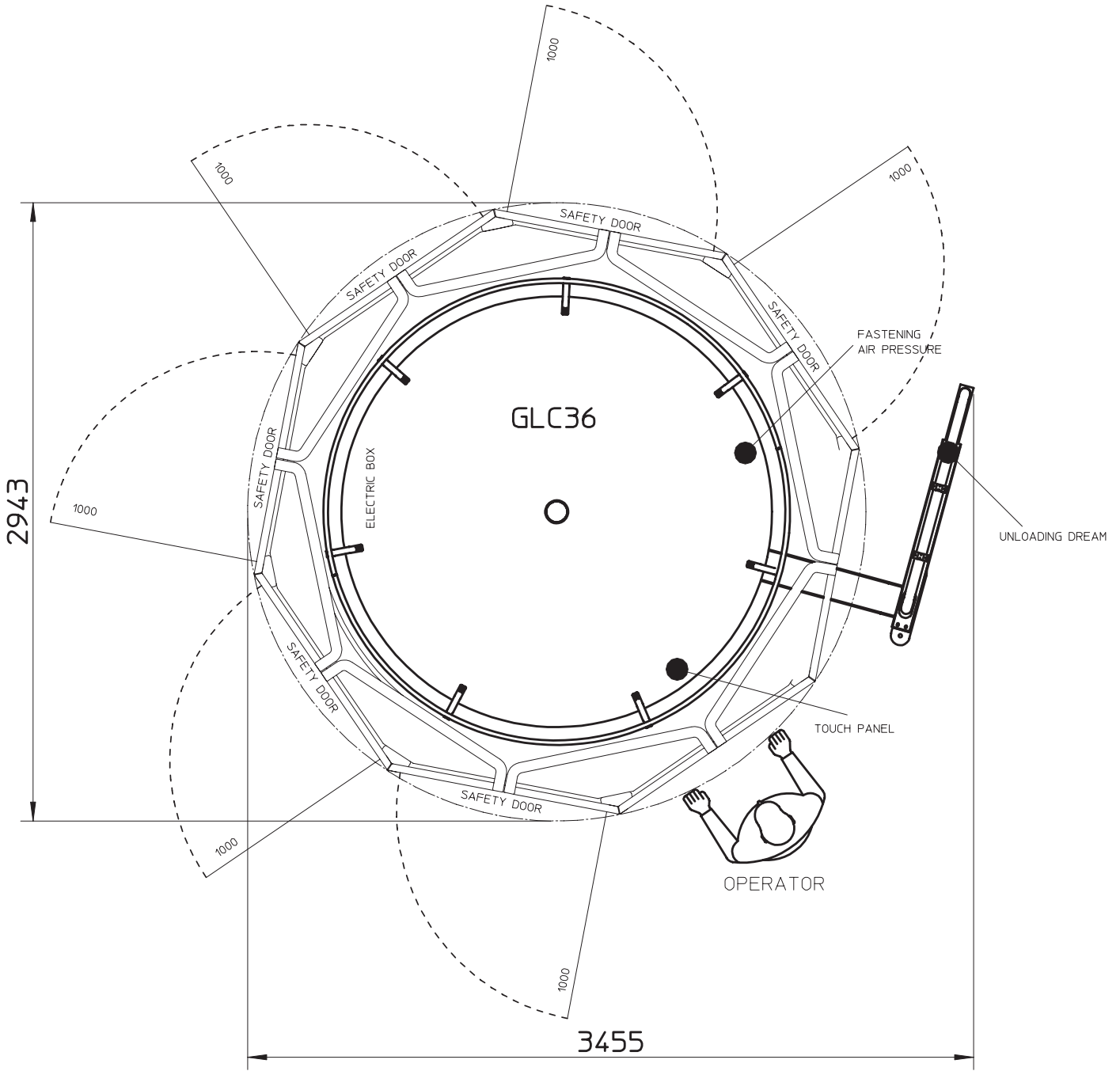



SANTONI SPA

Via Carlo Fenzi, 14 - 25135 Brescia - Italy
Tel. +39 030 37671 Fax +39 030 3767400

P.IVA e CF: IT 00273280172

info.santoni@santoni.com - www.santoni.com